

**MONTREAL - WITH HYBRID MIST BURNER**

## MONTREAL 800 mm - Front/Left - Hybrid Mist

This contemporary Montreal built-in fireplace, with an open front and left-side opening, comes with the innovative Hybrid Mist burner. A water-based flame effect is generated through atomised mist and side-mounted LED illumination, delivering a captivating and safe fireplace experience. Designed and produced in Denmark. Ideal as a stylish focal point for modern interiors.



### OPERATION

The model is equipped with an electronic bio burner and can be operated either with the included remote control, via the control panel on the burner or the DecoFlame App, available for both Android and Apple.

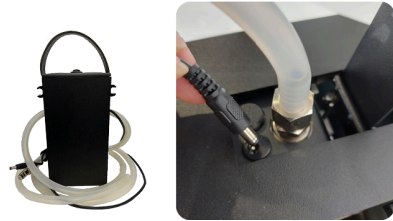
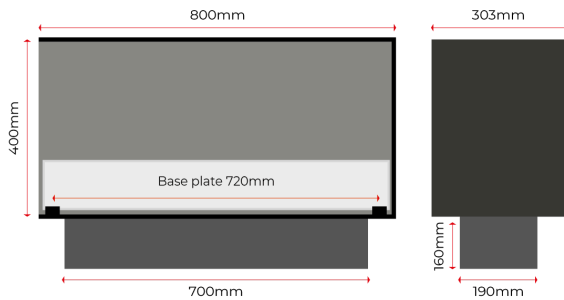

### ELECTRONIC PUMP

Included: External customised filling pump for safe and easy filling. Can also be used if the tank needs to be emptied.

### GENERAL INFORMATION

Model	Montreal 800 mm
Configuration	Open to Front and Left
Included Burner	Hybrid Mist 720
Operation Type	Electronic
Production	Made in Denmark

### DESIGN & MATERIALS

Material	Stainless steel / Powder coated aluminum
Finish	Standard black powder coating
Glass Quality	Tempered diamond clear glass
Standard Glass	2x Low Glass

**MONTREAL - WITH HYBRID MIST BURNER****PHYSICAL SPECIFICATIONS**

Gross Dimensions (mm)	W: 800 × H: 400 × D: 303
Glass Dimensions (mm)	Low Glass: L: 769 × H: 110 × T: 10 / L: 279 × H: 110 × T: 10
Weight: (kg)	35.0

**BURNER DETAILS**

Burner Model	Hybrid Mist 720
Fuel Type	Demineralised water
Flametray (mm)	
Flame Levels	6
Chimney	Not Required

**PERFORMANCE**

Capacity (L)	6.0
Max Level Burn Time (H)	48.0
Nominal Heat Output (kW)	N/A
Fuel consumption (ml/h)	125

**INSTALLATION REQUIREMENTS**

Cut-out Dimensions (mm)	W: 805 × H: 410 × D: 308
Minimum Room Size (m <sup>3</sup> )	N/A
Power Supply	230 V AC (220 V compatible), 50–60 Hz, earthed connection
Installation Environment	Indoor

**FEATURES**

Safety Features	Flame level Indikator / Water level Indikator
Add-on Features	Glassdoor / Bronze glass / Ceramic Firewood / BWT Water filter / Automatic BWT Water filter
Included Features	Vapour / LED Technology / Remote Control / App Operation / Large Fuel Tank / External Fuel Pump with Quick Connection

**DISCLAIMER – DECOFLAME A/S**

All product specifications and technical data are subject to change without prior notice and are considered accurate as of the date of publication. Decoflame A/S, including its affiliates, employees, agents and other representatives (collectively referred to as "Decoflame A/S"), disclaims all liability for any errors, inaccuracies, or omissions in this document or in any other product-related information. Decoflame A/S shall not be held liable for any damage, loss, or indirect consequences arising from the use, installation, or operation of the products, unless otherwise required under applicable law. It is the user's responsibility to ensure correct installation and usage in accordance with applicable safety standards and the manufacturer's instructions. No licence, whether express or implied, to any intellectual property rights is granted through this document. Customers who use or sell Decoflame A/S products for purposes not explicitly specified do so at their own risk and agree to indemnify Decoflame A/S against any claims or damages resulting from such use. Fuel consumption may vary depending on individual units, environmental conditions, and operating parameters. Product images are for illustrative purposes only and may differ from the actual product. This limitation of liability does not apply where it would conflict with mandatory consumer protection laws.

**MONTREAL - WITH HYBRID MIST BURNER**

# MONTREAL 1000 mm - Front/Left - Hybrid Mist

This contemporary Montreal built-in fireplace, with an open front and left-side opening, comes with the innovative Hybrid Mist burner. A water-based flame effect is generated through atomised mist and side-mounted LED illumination, delivering a captivating and safe fireplace experience. Designed and produced in Denmark. Ideal as a stylish focal point for modern interiors.



**OPERATION**

The model is equipped with an electronic bio burner and can be operated either with the included remote control, via the control panel on the burner or the DecoFlame App, available for both Android and Apple.

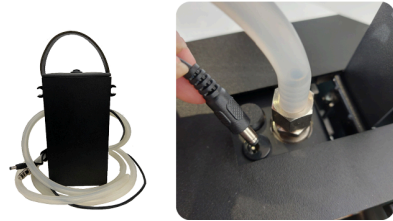
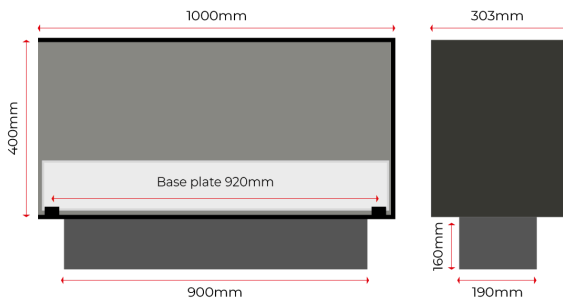

**ELECTRONIC PUMP**

Included: External customised filling pump for safe and easy filling. Can also be used if the tank needs to be emptied.

**GENERAL INFORMATION**

Model	Montreal 1000 mm
Configuration	Open to Front and Left
Included Burner	Hybrid Mist 920
Operation Type	Electronic
Production	Made in Denmark

**DESIGN & MATERIALS**

Material	Stainless steel / Powder coated aluminum
Finish	Standard black powder coating
Glass Quality	Tempered diamond clear glass
Standard Glass	2x Low Glass

**MONTREAL - WITH HYBRID MIST BURNER****PHYSICAL SPECIFICATIONS**

Gross Dimensions (mm)	W: 1000 × H: 400 × D: 303
Glass Dimensions (mm)	Low Glass: L: 769 × H: 110 × T: 10 / L: 279 × H: 110 × T: 10
Weight: (kg)	41.0

**BURNER DETAILS**

Burner Model	Hybrid Mist 920
Fuel Type	Demineralised water
Flametray (mm)	
Flame Levels	6
Chimney	Not Required

**PERFORMANCE**

Capacity (L)	8.0
Max Level Burn Time (H)	53.0
Nominal Heat Output (kW)	N/A
Fuel consumption (ml/h)	150

**INSTALLATION REQUIREMENTS**

Cut-out Dimensions (mm)	W: 1005 × H: 410 × D: 308
Minimum Room Size (m <sup>3</sup> )	N/A
Power Supply	230 V AC (220 V compatible), 50–60 Hz, earthed connection
Installation Environment	Indoor

**FEATURES**

Safety Features	Flame level Indikator / Water level Indikator
Add-on Features	Glassdoor / Bronze glass / Ceramic Firewood / BWT Water filter / Automatic BWT Water filter
Included Features	Vapour / LED Technology / Remote Control / App Operation / Large Fuel Tank / External Fuel Pump with Quick Connection

**DISCLAIMER – DECOFLAME A/S**

All product specifications and technical data are subject to change without prior notice and are considered accurate as of the date of publication. Decoflame A/S, including its affiliates, employees, agents and other representatives (collectively referred to as "Decoflame A/S"), disclaims all liability for any errors, inaccuracies, or omissions in this document or in any other product-related information. Decoflame A/S shall not be held liable for any damage, loss, or indirect consequences arising from the use, installation, or operation of the products, unless otherwise required under applicable law. It is the user's responsibility to ensure correct installation and usage in accordance with applicable safety standards and the manufacturer's instructions. No licence, whether express or implied, to any intellectual property rights is granted through this document. Customers who use or sell Decoflame A/S products for purposes not explicitly specified do so at their own risk and agree to indemnify Decoflame A/S against any claims or damages resulting from such use. Fuel consumption may vary depending on individual units, environmental conditions, and operating parameters. Product images are for illustrative purposes only and may differ from the actual product. This limitation of liability does not apply where it would conflict with mandatory consumer protection laws.

**MONTREAL - WITH HYBRID MIST BURNER**

## MONTREAL 1200 mm - Front/Left - Hybrid Mist

This contemporary Montreal built-in fireplace, with an open front and left-side opening, comes with the innovative Hybrid Mist burner. A water-based flame effect is generated through atomised mist and side-mounted LED illumination, delivering a captivating and safe fireplace experience. Designed and produced in Denmark. Ideal as a stylish focal point for modern interiors.



### OPERATION

The model is equipped with an electronic bio burner and can be operated either with the included remote control, via the control panel on the burner or the DecoFlame App, available for both Android and Apple.

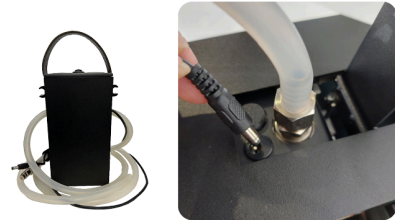
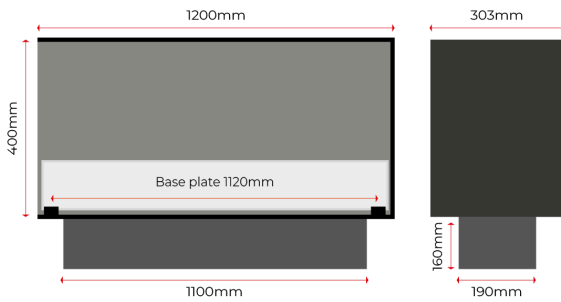

### ELECTRONIC PUMP

Included: External customised filling pump for safe and easy filling. Can also be used if the tank needs to be emptied.

### GENERAL INFORMATION

Model	Montreal 1200 mm
Configuration	Open to Front and Left
Included Burner	Hybrid Mist 1120
Operation Type	Electronic
Production	Made in Denmark

### DESIGN & MATERIALS

Material	Stainless steel / Powder coated aluminum
Finish	Standard black powder coating
Glass Quality	Tempered diamond clear glass
Standard Glass	2x Low Glass

**MONTREAL - WITH HYBRID MIST BURNER****PHYSICAL SPECIFICATIONS**

Gross Dimensions (mm)	W: 1200 × H: 400 × D: 303
Glass Dimensions (mm)	Low Glass: L: 769 × H: 110 × T: 10 / L: 279 × H: 110 × T: 10
Weight: (kg)	47.0

**BURNER DETAILS**

Burner Model	Hybrid Mist 1120
Fuel Type	Demineralised water
Flametray (mm)	
Flame Levels	6
Chimney	Not Required

**PERFORMANCE**

Capacity (L)	8.0
Max Level Burn Time (H)	53.0
Nominal Heat Output (kW)	N/A
Fuel consumption (ml/h)	150

**INSTALLATION REQUIREMENTS**

Cut-out Dimensions (mm)	W: 1205 × H: 410 × D: 308
Minimum Room Size (m <sup>3</sup> )	N/A
Power Supply	230 V AC (220 V compatible), 50–60 Hz, earthed connection
Installation Environment	Indoor

**FEATURES**

Safety Features	Flame level Indikator / Water level Indikator
Add-on Features	Glassdoor / Bronze glass / Ceramic Firewood / BWT Water filter / Automatic BWT Water filter
Included Features	Vapour /LED Technology / Remote Control / App Operation / Large Fuel Tank / External Fuel Pump with Quick Connection

**DISCLAIMER – DECOFLAME A/S**

All product specifications and technical data are subject to change without prior notice and are considered accurate as of the date of publication. Decoflame A/S, including its affiliates, employees, agents and other representatives (collectively referred to as "Decoflame A/S"), disclaims all liability for any errors, inaccuracies, or omissions in this document or in any other product-related information. Decoflame A/S shall not be held liable for any damage, loss, or indirect consequences arising from the use, installation, or operation of the products, unless otherwise required under applicable law. It is the user's responsibility to ensure correct installation and usage in accordance with applicable safety standards and the manufacturer's instructions. No licence, whether express or implied, to any intellectual property rights is granted through this document. Customers who use or sell Decoflame A/S products for purposes not explicitly specified do so at their own risk and agree to indemnify Decoflame A/S against any claims or damages resulting from such use. Fuel consumption may vary depending on individual units, environmental conditions, and operating parameters. Product images are for illustrative purposes only and may differ from the actual product. This limitation of liability does not apply where it would conflict with mandatory consumer protection laws.

**MONTREAL - WITH HYBRID MIST BURNER**

## MONTREAL 800 mm - Front/Right - Hybrid Mist

This sleek Montreal built-in fireplace, with an open front and right-side design, includes the innovative Hybrid Mist burner. It creates a flame illusion using water vapour technology and LED lighting – a cosy and flame-free alternative. Designed and produced in Denmark. Ideal as a stylish focal point for modern interiors.



### OPERATION

The model is equipped with an electronic bio burner and can be operated either with the included remote control, via the control panel on the burner or the DecoFlame App, available for both Android and Apple.

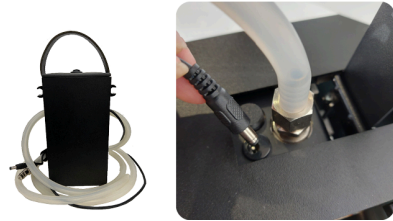
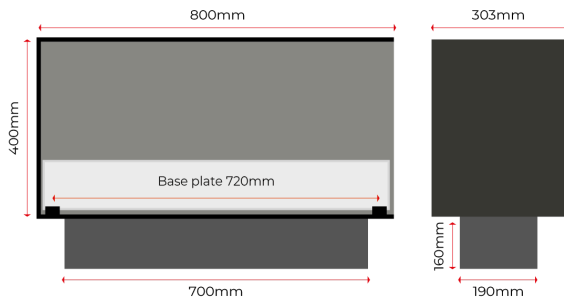

### ELECTRONIC PUMP

Included: External customised filling pump for safe and easy filling. Can also be used if the tank needs to be emptied.

### GENERAL INFORMATION

Model	Montreal 800 mm
Configuration	Open to Front and Right
Included Burner	Hybrid Mist 720
Operation Type	Electronic
Production	Made in Denmark

### DESIGN & MATERIALS

Material	Stainless steel / Powder coated aluminum
Finish	Standard black powder coating
Glass Quality	Tempered diamond clear glass
Standard Glass	2x Low Glass

**MONTREAL - WITH HYBRID MIST BURNER****PHYSICAL SPECIFICATIONS**

Gross Dimensions (mm)	W: 800 × H: 400 × D: 303
Glass Dimensions (mm)	Low Glass: L: 769 × H: 110 × T: 10 / L: 271 × H: 110 × T: 10
Weight: (kg)	35.0

**BURNER DETAILS**

Burner Model	Hybrid Mist 720
Fuel Type	Demineralised water
Flametray (mm)	
Flame Levels	6
Chimney	Not Required

**PERFORMANCE**

Capacity (L)	6.0
Max Level Burn Time (H)	48.0
Nominal Heat Output (kW)	N/A
Fuel consumption (ml/h)	125

**INSTALLATION REQUIREMENTS**

Cut-out Dimensions (mm)	W: 805 × H: 410 × D: 308
Minimum Room Size (m <sup>3</sup> )	N/A
Power Supply	230 V AC (220 V compatible), 50–60 Hz, earthed connection
Installation Environment	Indoor

**FEATURES**

Safety Features	Flame level Indikator / Water level Indikator
Add-on Features	Glassdoor / Bronze glass / Ceramic Firewood / BWT Water filter / Automatic BWT Water filter
Included Features	Vapour / LED Technology / Remote Control / App Operation / Large Fuel Tank / External Fuel Pump with Quick Connection

**DISCLAIMER – DECOFLAME A/S**

All product specifications and technical data are subject to change without prior notice and are considered accurate as of the date of publication. Decoflame A/S, including its affiliates, employees, agents and other representatives (collectively referred to as "Decoflame A/S"), disclaims all liability for any errors, inaccuracies, or omissions in this document or in any other product-related information. Decoflame A/S shall not be held liable for any damage, loss, or indirect consequences arising from the use, installation, or operation of the products, unless otherwise required under applicable law. It is the user's responsibility to ensure correct installation and usage in accordance with applicable safety standards and the manufacturer's instructions. No licence, whether express or implied, to any intellectual property rights is granted through this document. Customers who use or sell Decoflame A/S products for purposes not explicitly specified do so at their own risk and agree to indemnify Decoflame A/S against any claims or damages resulting from such use. Fuel consumption may vary depending on individual units, environmental conditions, and operating parameters. Product images are for illustrative purposes only and may differ from the actual product. This limitation of liability does not apply where it would conflict with mandatory consumer protection laws.

**MONTREAL - WITH HYBRID MIST BURNER**

## MONTREAL 1000 mm - Front/Right - Hybrid Mist

This sleek Montreal built-in fireplace, with an open front and right-side design, includes the innovative Hybrid Mist burner. It creates a flame illusion using water vapour technology and LED lighting – a cosy and flame-free alternative. Designed and produced in Denmark. Ideal as a stylish focal point for modern interiors.



### OPERATION

The model is equipped with an electronic bio burner and can be operated either with the included remote control, via the control panel on the burner or the DecoFlame App, available for both Android and Apple.

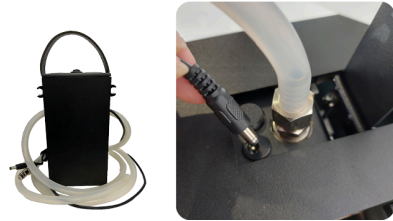
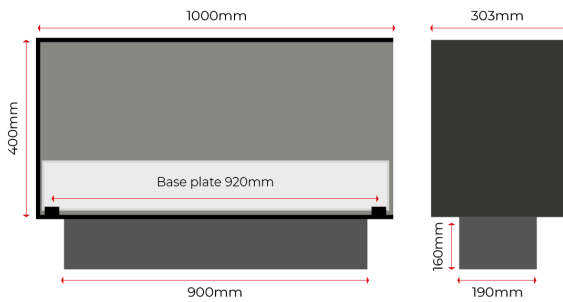

### ELECTRONIC PUMP

Included: External customised filling pump for safe and easy filling. Can also be used if the tank needs to be emptied.

### GENERAL INFORMATION

Model	Montreal 1000 mm
Configuration	Open to Front and Right
Included Burner	Hybrid Mist 920
Operation Type	Electronic
Production	Made in Denmark

### DESIGN & MATERIALS

Material	Stainless steel / Powder coated aluminum
Finish	Standard black powder coating
Glass Quality	Tempered diamond clear glass
Standard Glass	2x Low Glass

**MONTREAL - WITH HYBRID MIST BURNER****PHYSICAL SPECIFICATIONS**

Gross Dimensions (mm)	W: 1000 × H: 400 × D: 303
Glass Dimensions (mm)	Low Glass: L: 769 × H: 110 × T: 10 / L: 271 × H: 110 × T: 10
Weight: (kg)	41.0

**BURNER DETAILS**

Burner Model	Hybrid Mist 920
Fuel Type	Demineralised water
Flametray (mm)	
Flame Levels	6
Chimney	Not Required

**PERFORMANCE**

Capacity (L)	8.0
Max Level Burn Time (H)	53.0
Nominal Heat Output (kW)	N/A
Fuel consumption (ml/h)	150

**INSTALLATION REQUIREMENTS**

Cut-out Dimensions (mm)	W: 1005 × H: 410 × D: 308
Minimum Room Size (m <sup>3</sup> )	N/A
Power Supply	230 V AC (220 V compatible), 50–60 Hz, earthed connection
Installation Environment	Indoor

**FEATURES**

Safety Features	Flame level Indikator / Water level Indikator
Add-on Features	Glassdoor / Bronze glass / Ceramic Firewood / BWT Water filter / Automatic BWT Water filter
Included Features	Vapour / LED Technology / Remote Control / App Operation / Large Fuel Tank / External Fuel Pump with Quick Connection

**DISCLAIMER – DECOFLAME A/S**

All product specifications and technical data are subject to change without prior notice and are considered accurate as of the date of publication. Decoflame A/S, including its affiliates, employees, agents and other representatives (collectively referred to as "Decoflame A/S"), disclaims all liability for any errors, inaccuracies, or omissions in this document or in any other product-related information. Decoflame A/S shall not be held liable for any damage, loss, or indirect consequences arising from the use, installation, or operation of the products, unless otherwise required under applicable law. It is the user's responsibility to ensure correct installation and usage in accordance with applicable safety standards and the manufacturer's instructions. No licence, whether express or implied, to any intellectual property rights is granted through this document. Customers who use or sell Decoflame A/S products for purposes not explicitly specified do so at their own risk and agree to indemnify Decoflame A/S against any claims or damages resulting from such use. Fuel consumption may vary depending on individual units, environmental conditions, and operating parameters. Product images are for illustrative purposes only and may differ from the actual product. This limitation of liability does not apply where it would conflict with mandatory consumer protection laws.

**MONTREAL - WITH HYBRID MIST BURNER**

## MONTREAL 1200 mm - Front/Right - Hybrid Mist

This sleek Montreal built-in fireplace, with an open front and right-side design, includes the innovative Hybrid Mist burner. It creates a flame illusion using water vapour technology and LED lighting – a cosy and flame-free alternative. Designed and produced in Denmark. Ideal as a stylish focal point for modern interiors.



**OPERATION**

The model is equipped with an electronic bio burner and can be operated either with the included remote control, via the control panel on the burner or the DecoFlame App, available for both Android and Apple.

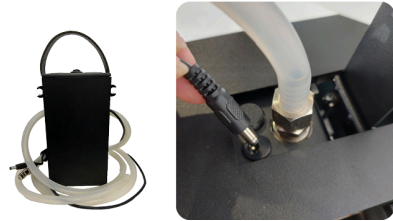
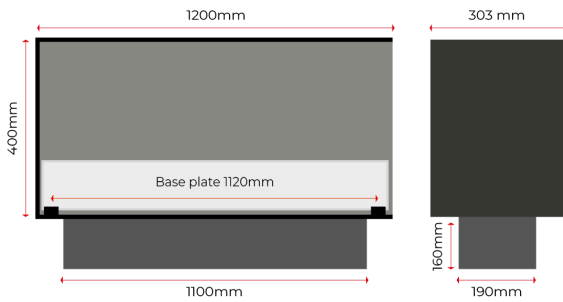

**ELECTRONIC PUMP**

Included: External customised filling pump for safe and easy filling. Can also be used if the tank needs to be emptied.

**GENERAL INFORMATION**

Model	Montreal 1200 mm
Configuration	Open to Front and Right
Included Burner	Hybrid Mist 1120
Operation Type	Electronic
Production	Made in Denmark

**DESIGN & MATERIALS**

Material	Stainless steel / Powder coated aluminum
Finish	Standard black powder coating
Glass Quality	Tempered diamond clear glass
Standard Glass	2x Low Glass

**MONTREAL - WITH HYBRID MIST BURNER****PHYSICAL SPECIFICATIONS**

Gross Dimensions (mm)	W: 1200 × H: 400 × D: 303
Glass Dimensions (mm)	Low Glass: L: 769 × H: 110 × T: 10 / L: 271 × H: 110 × T: 10
Weight: (kg)	47.0

**BURNER DETAILS**

Burner Model	Hybrid Mist 1120
Fuel Type	Demineralised water
Flametray (mm)	
Flame Levels	6
Chimney	Not Required

**PERFORMANCE**

Capacity (L)	8.0
Max Level Burn Time (H)	53.0
Nominal Heat Output (kW)	N/A
Fuel consumption (ml/h)	150

**INSTALLATION REQUIREMENTS**

Cut-out Dimensions (mm)	W: 1205 × H: 410 × D: 308
Minimum Room Size (m <sup>3</sup> )	N/A
Power Supply	230 V AC (220 V compatible), 50–60 Hz, earthed connection
Installation Environment	Indoor

**FEATURES**

Safety Features	Flame level Indikator / Water level Indikator
Add-on Features	Glassdoor / Bronze glass / Ceramic Firewood / BWT Water filter / Automatic BWT Water filter
Included Features	Vapour /LED Technology / Remote Control / App Operation / Large Fuel Tank / External Fuel Pump with Quick Connection

**DISCLAIMER – DECOFLAME A/S**

All product specifications and technical data are subject to change without prior notice and are considered accurate as of the date of publication. Decoflame A/S, including its affiliates, employees, agents and other representatives (collectively referred to as "Decoflame A/S"), disclaims all liability for any errors, inaccuracies, or omissions in this document or in any other product-related information. Decoflame A/S shall not be held liable for any damage, loss, or indirect consequences arising from the use, installation, or operation of the products, unless otherwise required under applicable law. It is the user's responsibility to ensure correct installation and usage in accordance with applicable safety standards and the manufacturer's instructions. No licence, whether express or implied, to any intellectual property rights is granted through this document. Customers who use or sell Decoflame A/S products for purposes not explicitly specified do so at their own risk and agree to indemnify Decoflame A/S against any claims or damages resulting from such use. Fuel consumption may vary depending on individual units, environmental conditions, and operating parameters. Product images are for illustrative purposes only and may differ from the actual product. This limitation of liability does not apply where it would conflict with mandatory consumer protection laws.